



**Baureihe 46 - Type 46**  
 2/2 - Wege Magnetventil  
 2/2 - Way solenoid valve

**Standardtype**

Ventil in Ruhestellung geschlossen-(NC). Bei erregtem Magnet baut sich die Druckdifferenz von der Sekundärseite des Kolbens über die Servobohrung ab. Die wirksame Druckdifferenz hebt den Kolben vom Ventilsitz ab. Der angegebene Mindestdruck muß als Druckdifferenz immer vorhanden sein.

**Standard type**

Valve normally closed - NC. When energised, the pressure decomposes on the secondary side of the piston. Then the pressure differential ( $\Delta p$ ) lifts the piston from the seat (orifice). A pressure differential ( $\Delta p$ ) is necessary for accurate operation.



Steuerungsart: Type of control:	Servogesteuert Pilot operated	Dichtung: Sealing:	NBR NBR
Konstruktion: Construction:	Kolbensitzventil Piston design	Metall. Innenteile: Metallic internals:	Edelstahl 1.4104 Stainless steel AISI 430F
Anschluß: Connection:	G1/4-G1, DIN ISO 228 G1/4-G1, DIN ISO 228	Einbaulage: Installation:	beliebig, vorzugsw. mit stehendem Magneten actuator in any pos., preferable in upright pos.
Druck: Pressure:	1-max. 150 bar (s. Tabelle) 1-max. 150 bar (see table)	Anschlußspannung: Supply voltage:	AC: 24,42,110,230V 50/60Hz DC: 24,110,205V=
Durchflußmedium: Medium:	Neutrale, gasförmige u. flüssige Medien Neutral, gaseous and liquid medium	Spannungstoleranz: Voltage tolerance:	+5% / -10% +5% / -10%
Viskosität: Viscosity:	22mm <sup>2</sup> /s 22mm <sup>2</sup> /s	Leistungsaufnahme: Power-consumption:	1702 / 3702 =25 Watt 1322 / 3322 =30 Watt 4242 / 5242 =46 Watt
Mediumtemperatur: Medium temperature:	-10 bis +80°C -10 up to +80°C	Schutzart: Protection class:	IP65 nach DIN 40050 IP65 according to DIN 40050
Umgebungstemperatur: Ambient temperature:	+35°C +35°C	Einschaltdauer: Duty factor:	100% ED-VDE 0580 100% ED-VDE 0580
Ventilgehäuse: Body material:	../09../ = Edelstahl 1.4104 (bis PN100) Stainless steel (AISI 430F) (up to PN100) ../08../ = Edelstahl 1.4581 (bis PN100) Stainless steel (AISI 316Ti) (up to PN100) ../06../ = Edelstahl 1.4305 (bis PN150) Stainless steel (AISI 303) (up to PN 150)	Kabelanschluß: Cable connection:	Gerätestecker DIN 43650 / Klemmkasten DIN 43650 - plug / Terminal box

Edelstahl 1.4581- Stainless steel (AISI 316Ti) / Edelstahl 1.4104 - Stainless steel (AISI 430F)

G	Sitz Orifice Ømm	Kv-Wert Flow-rate m <sup>3</sup> /h	Standardtype Standard type	max. Druck bei Magnettype max. pressure regarding solenoid type		
				.702	.322	.242
1/4	8	1,0	B4621/0801/....	1-100	-	-
3/8	8	1,2	B4622/0801/....	1-100	-	-
1/2	8	2,0	B4623/0801/....	1-100	-	-
1/2	13	2,5	A4623/0901/....	-	1-100	-
3/4	25	4,3	A4624/0901/....	-	1-100	-
1	25	8,0	A4625/0901/....	-	1-100	-

Edelstahl 1.4305 / Stainless steel (AISI 303)

1/2	13	2,5	A4623/0601/....	-	1-150	-
3/4	25	4,3	A4624/0601/....	-	-	1-150
1	25	8,0	A4625/0601/....	-	-	1-150

Maßzeichnung Standardausführung  
Dimensional drawing of standard type

Maßzeichnung mit Magnet .702  
Dimensional drawing with solenoid .702

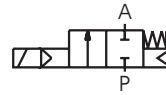

Schaltfunktion/function:  
In Ruhestellung gesperrt - NC.  
Normally closed - NC.

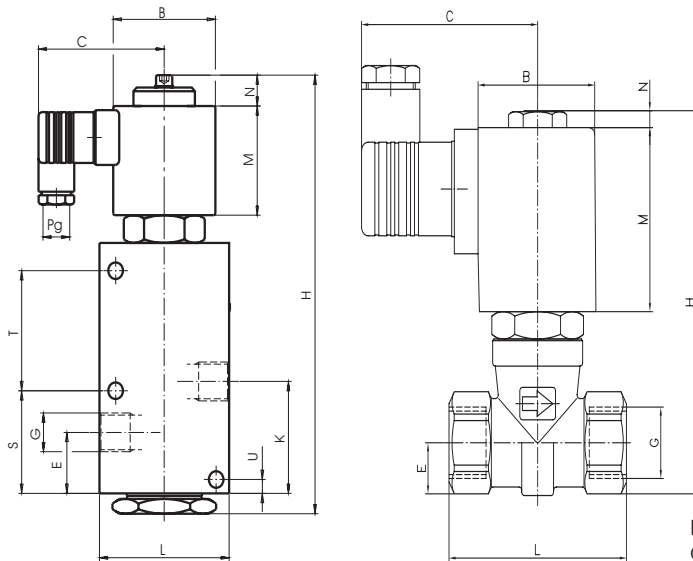

Anschlußplan / Connection diagram

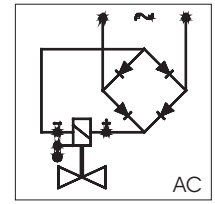
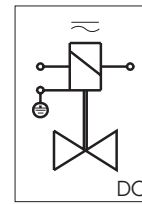

Für Gleichspannung.  
For DC.

Mit vorgeschaltetem Gleichrichter  
für Wechselspannung.  
With rectifier for AC current.

Erdung oder Schutzschaltung nach Vorschrift des zuständigen EVU.  
Grounding or earthing of the protective circuit in accordance with regulations of the responsible electric supply company.

Absicherung entsprechend der Stromaufnahme vorsehen.  
Appropriate protection according to the power-consumption.

Magnet Solenoid	.702			.322			.242	
Type	4621	4622	4623	4623	4624	4625	4624	4625
G	1/4	3/8	1/2	1/2	3/4	1	3/4	1
B	35x35	35x35	35x35	Ø63	Ø63	Ø63	Ø77	Ø77
C	66	66	66	76	76	76	82	82
E	17,5	17,5	17,5	27	47	47	47	47
H	130	130	130	200	260	260	285	285
K	17,5	17,5	17,5	63	83	83	83	83
L	65	65	65	70	100	100	100	100
M	50	50	50	59	59	59	70	70
N	10	10	10	16	16	16	19	19
S	-	-	-	-	25	25	25	25
T	-	-	-	-	125	125	125	125
Pg	11	11	11	11	11	11	11	11
kg	1,1	1,1	1,0	5,5	7,5	7,4	8,7	8,6

Alle Angaben sind freibleibend und unverbindlich / All technical specifications are without obligation!

Weitere Ventilausführungen

/

Valve options

Stromlos geöffnet= NO  
Non energised open= NO

Handbetätigung= HA  
Manual override= HA

Dichtung= FKM, EPDM, PTFE  
Seal= FKM, EPDM, PTFE

Öl- und fettfrei= OF  
Free of oil and grease= OF (for oxygen application)

Andere Durchflußmedien und Viskositäten  
Varying medium and viscosity ranges

Buntmetallfrei= BF  
Free of non-ferrous metal= BF

Ex-Schutz= Ex II 2G EEx em II T4  
Explosion proof= Ex II 2G EEx d II c T4 (T5 + T6)

Weitere Druckbereiche = bis 450 Bar  
Further pressure ranges = up to 450 Bar



Stückliste - Parts list

- K1.1 Armatur / Valve body
- \*K3.1 Kolben / Piston
- \*K3.2 O-Ring / O-ring
- K5.1 Magnethülse / Solenoid tube
- \*K5.2 Magnetanker / Solenoid plunger
- \*K5.3 Dichtung / Sealing
- \*K5.4 Kerbstift / Grooved pin
- \*K5.5 Druckfeder / Spring
- K5.6 Scheibe / Disk
- K5.7 Sicherungsscheibe / Locking disk
- K5.8 Befestigungsmutter / Mounting nut
- K6.1 Magnetspule / Solenoid
- K7.1 Stecker o. Klemmkasten / Plug or terminal box

\* = Bestandteil des Ersatzteilpäckchens  
(je nach Ausführung freibleibend)  
\* = Part of the service set. (These specifications are without obligation).

Stückliste - Parts list

- K1.1 Armatur / Valve body
- K1.2 Deckel / Bonnet
- \*K3.1 Spindel -HA / Spindle -HA
- \*K3.2 Verschraubung -HA / Screw joint -HA
- \*K3.3 O-Ring / O-ring
- K3.4 Spindel / Spindle
- \*K3.5 Dichtung / Seal
- \*K3.6 Feder / Spring
- \*K3.7 Verschlußschraube / Screw
- \*K3.8 Dichtung / Seal
- \*K3.9 Scheibe / Disk
- \*K3.10 Schraube / Screw
- \*K3.11 Handrad / Hand wheel
- K3.12 Feder / Spring
- \*K3.13 Kolben / Piston
- \*K3.14 O-Ring / O-ring
- \*K3.15 Kolbenführungsband / Piston guide band
- \*K3.16 Feder / Spring
- K3.17 O-Ring / O-ring
- K5.1 O-Ring / O-ring
- K5.2 Magnethülse / Solenoid tube
- K5.3 Magnetanker / Solenoid plunger
- K5.4 Druckstück / Pressure piece
- K5.5 O-Ring / O-ring
- K5.6 O-Ring / O-ring
- K5.7 Scheibe / Disk
- K5.8 Schraube / Screw
- K6.1 Magnet / Solenoid
- K7.1 Stecker o. Klemmkasten / Plug or terminal box
- K3.18 Scheibe / Disk
- K3.19 Spindel-HA / Spindle
- K3.20 Verschraubung / Connection
- \*K3.21 Nutring / U-ring
- K3.22 Handrad / Handwheel
- K3.23 Scheibe / Disk
- K.24 Schraube / Screw

\* = Bestandteil des Ersatzteilpäckchens  
(je nach Ausführung freibleibend)  
\* = Part of the service set. (These specifications are without obligation).

Baureihe / Type A4621-A4623  
G1/4-G1/2, DN13

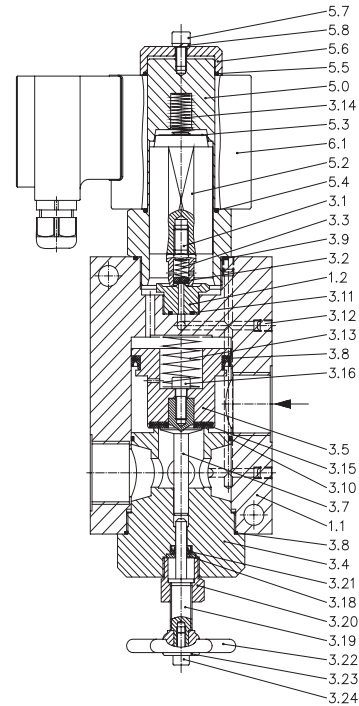

Baureihe / Type A4624 - A4625  
Ausführung mit Handbetätigung - HA  
With manual operation - HA

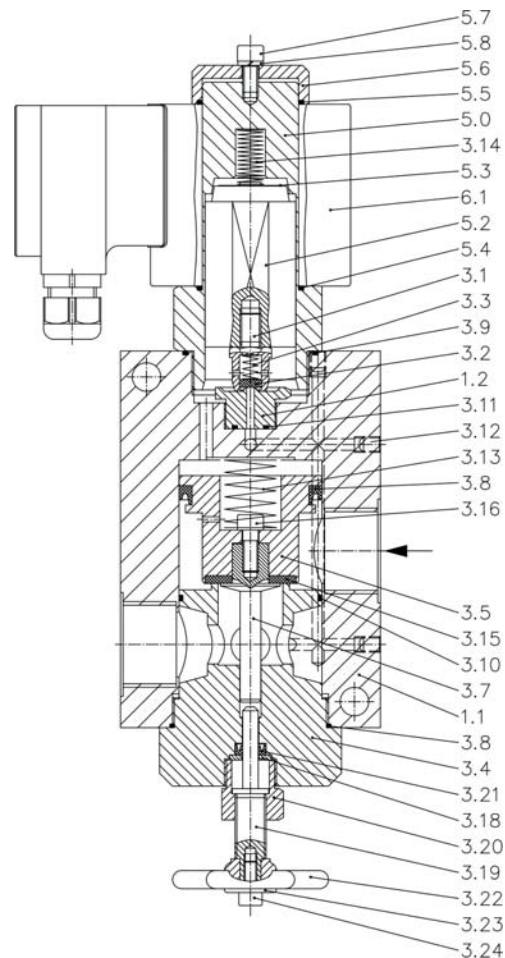

**Stückliste - Parts list**

 Baureihe / Type A4624-A4625  
 Standardausführung G3/4-G1  
 Standard type G3/4-G1

- K1.1 Armatur / Valve body
- K1.2 Vorsteuersitz / Rough control seat
- \*K3.1 Vorsteuerspindel / Pilot seat
- \*K3.2 Dichtung / Seal
- \*K3.3 Feder / Spring
- K3.4 Verschraubung / Screw joint
- \*K3.5 Kolben / Piston
- \*K3.6 Spindel / Spindle
- \*K3.7 Nutring / U-cup seal
- \*K3.8 O-Ring / O-ring
- \*K3.9 O-Ring / O-ring
- \*K3.10 O-Ring / O-ring
- \*K3.11 O-Ring / O-ring
- K3.12 Gewindestift / Threaded pin
- \*K3.13 Feder / Spring
- \*K3.14 Feder / Spring
- \*K3.15 Dichtung / Seal
- \*K3.16 Zylinderschraube / Cylinder screw
- K3.17 Sitzscheibe / Disk
- K5.1 Magnethülse / Solenoid tube
- K5.2 Magnetanker / Solenoid plunger
- K5.3 Scheibe / Disk
- K5.4 O-Ring / O-ring
- K5.5 O-Ring / O-ring
- K5.6 Druckstück / Pressure piece
- K5.7 Zylinderschraube / Cylinder screw
- K5.8 Sicherungsscheibe / Locking disk
- K6.1 Magnetspule / Solenoid
- K7.1 Stecker o. Klemmkasten / Plug or terminal box

\* = Bestandteil des Ersatzteilpäckchens  
 (je nach Ausführung freibleibend)  
 \* = Part of the service set. (These  
 specifications are without obligation).

